



Goulburn High School Newsletter



9/12

14th September 2017 goulburn-h.school@det.nsw.edu.au

Science Week at GHS

Students prepared for weeks to participate in the Science Fair Challenge and Holly Caffery, Charlotte Hargan and Joshua Porter, Year 9 students, achieved the highest results this year. Congratulations all.



R U OK day presentation with Mission Australia and actor Steve Bastoni

Mrs Reece snared a picture at the beginning of the R U OK presentation in the library for our year 9 and 10 students. Mr Bastoni explained why he became a R U OK ambassador right away, telling our students that he lost a good mate to suicide when he was only a teenager and that this tragic event made him realise how important mental health can be to all of us.





Principal's Report

As Year 12 approach their final weeks at school prior to the vital revision they will undertake during the next holidays, I reflect on their past 6 years at Goulburn High. The student cohort that started in 2012 differs somewhat to the group that sits the HSC this year. Some have moved from the area, others have moved school and some have moved onto work or TAFE. For those that remain, I congratulate you and wish you well for your future examinations and life after school. I believe that Goulburn High has provided you with the skills and education that will ensure you are able to make a success of your future.

Year 11 are currently undertaking their end of preliminary course examinations and I wish them well in their endeavours and am looking forward to the efforts they will produce as they start their HSC year.

At the end of this term, the Year 11 Great Barrier Reef trip will provide students with the experience of a lifetime, sight seeing and snorkelling amongst coral reefs, witnessing a colourful array of marine life and experiencing life on the far north coast of Queensland. Safe travels.

Year 5 and 6 students from our partner primary schools will continue to experience focus days. Students have been extremely excited and have thoroughly enjoyed these days.

Term 4 will involve Year 6 students in more opportunities to visit our school, enhancing their transition into high school. Students will undergo an Entrance Examination, which will provide further information to assist the smooth transition of Year 6 into Year 7, 2018. If parents of current Year 6 students have any questions regarding school next year, please contact Mrs Gina Handley through the front office.

Next year we will be running an Enrichment Class for Year 7 in the key subject areas on a semester basis, which will provide students with special aptitude in certain areas with an opportunity to be extended. A first for Goulburn High.

I will take this opportunity to remind all parents that we are a full uniform school and our school uniform can be purchased through the canteen on a Monday and Thursday. Term 4 usually means a return to warmer weather so old summer uniforms may not fit anymore so more may need to be purchased.

Regards,

Paul Hogan

Principal

What a Term in Science!

Term 3 week 5 is National Science Week. Goulburn High School has celebrated this event by being involved in a variety of activities.

Students from years 7-10 from Goulburn High entered their projects into the **Annual Science Fair**. This year the Maths Faculty took on the challenge of running the Year 8 projects which has allowed the development of STEM (Science, Technology, Engineering and Maths) at Goulburn High School. This is a very exciting development which is sure to support our students in successful skill development for future employment. Unfortunately we lost our major sponsor for this year and are currently looking for a business to support the 2018 Science Fair.

The winners were:

The 10 projects selected for this year's **UOW Science Fair Team** will be finalised by the end of the term with all the finalists having the chance to represent the school. Students wishing to represent the school will need to do a short presentation to a small group of judges.

Year 10 students have been involved in the first **GCOPS STEM** activity. Year 10 students from GHS and MHS went to local primary schools during Science Week. They supported year 3 and 4 students to work out the number of rubber bands needed to create an egg bungee. The project involved assessing properties of different materials, gathering data and extrapolating the data to predict the number of rubber bands. The top team from each year 3/4 class is coming to Goulburn High School to participate in the Grand Finals. A big congratulations needs to go out to all students involved. They represented the school in a positive and respectful way.

This year's **Robotics Teams** have started their competition. We have two EDR teams (metal) and 3 IQ (plastic) teams. All students have been working hard on their designs and are going to compete in their first Scrimmage on the 19th September. The first Scrimmage is going to be held at Goulburn High with students from as far away as Wodonga attending. Later in the year Goulburn has been selected to hold the NSW state finals on Saturday 19 November. This is a great opportunity for our students so if you want to come along or help out, put the date in your diary to keep it free.

A big thank you to all the support Goulburn High School has received this term for Science and STEM. Without student, parent and community support these programs would not be able to run. If you have any ideas or want to support a program please contact the school and ask to speak to Katherine Hyland (HT Science).





Science Week Winners

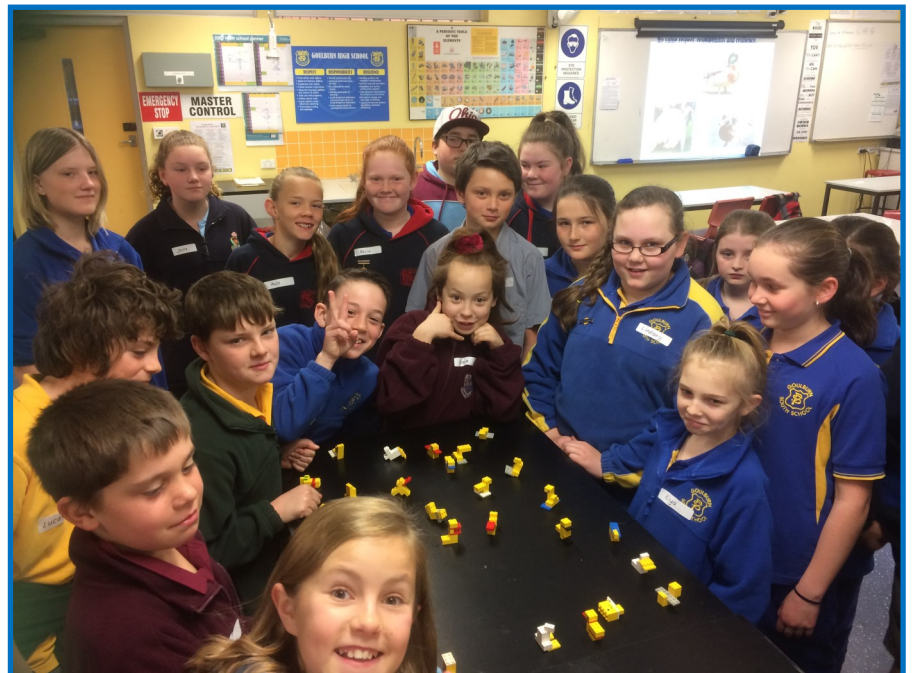



Science and Engineering Challenge

On the 14th and 15th August a group of around 20 Goulburn High School students travelled to represent the Southern Tablelands Region in the state Science and Engineering Challenge. We were accompanied by Mr Smith and Ms Ryman and stayed at the local youth hostel. After a long 5 and a half hour bus trip we were able to stretch our legs with a stroll and some sport on the beach, enjoyed by all. On the Thursday, the groups competed in variety of events such as creating prosthetic hands out of straws, making catapults and of course the highlight of the event, the Bridge Challenge. The students performed admirably on the day with many groups performing well in their challenges, with GHS coming 8th on the day. The students competed against an array of schools such as SHORE and Keira High School. We all thoroughly enjoyed this experience to develop our STEM, leadership and teamwork skills.

Charlotte Hargan, Year 9

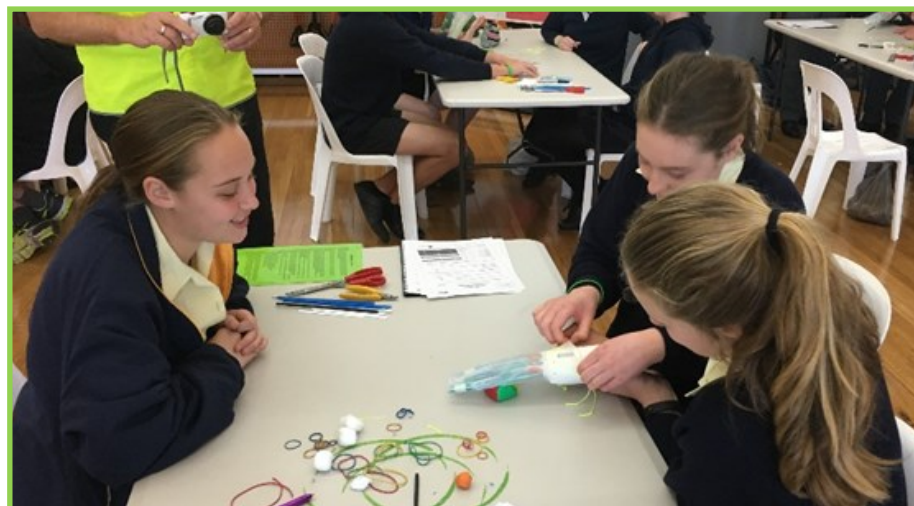

FROM THE SPORTS DESK



Joey gets GOLD.....twice

Joseph Kremer has achieved outstanding success at the NSW Combined High Schools Athletics Carnival held last week.

Joey won Gold in the 17+ years Discus on the Wednesday, throwing 45.22m.

He then backed this up on Friday in the Javelin event and won Gold, throwing 61.90m.

This amazing achievement is a credit to the hard work Joey has put into his chosen sport. He has dedicated his time to many training sessions and his determination and skill have seen him achieve great success.

Everyone at Goulburn High School is extremely proud!

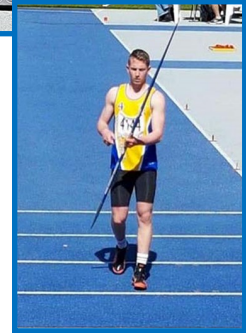

NSW Combined High Schools Athletics Carnival

Goulburn High School would also like to congratulate Brandyn Law who competed in the 16 years Boys Triple Jump. Brandyn placed 10th. Congratulations on a great achievement!

Ursula Kemmis competed in the 14 years girls 3000m, finishing in 9th place. Ursula is competing an age group above her actual age, so this is a fantastic achievement!



South Coast Basketball Knockout

The under 15 Goulburn High School Basketball Team competed in the South Coast Basketball Knockout tournament in Wollongong on the 31st August. The boy's first game was forfeited and they played a scratch match against Figtree 2 which they won by 10. They moved onto the semi-final against Nowra High School. The boys were unlucky and went down to Nowra by 5 points. It was a massive effort from all of them. They are commended on their tenacity and reliance. Congratulations to all the boys on making it to the South Coast Knockout.

Around the grounds

Congratulations to Bailey Stewart who has been successful in being selected in the NSW D-League Basketball Squad. 40 players were chosen with 20 coming from Country NSW and 20 from NSW Metro. Bailey will be placed into one of four teams who will compete against each other over 3 weekends. Good luck Bailey!



Rugby Union

Congratulations to all of the boys who competed in the Goulburn Rugby Championships on the 6th September. All students displayed great resilience to continue to compete on a cold and windy Goulburn day.

With many players coming from a Rugby League background, the students demonstrated their ability to adapt to the fast-paced format of Rugby Union. The students continued to improve throughout the day as they faced experienced Trinity teams who play together on a weekly basis. The Years 7 & 8 team drew one match and unfortunately went down in the other games by a narrow margin. The Years 9 & 10 boys had one win and one draw during their matches and demonstrated resilience as they found themselves without any substitutions due to injuries to Ken Lewis and Rhys Rakete.

For the Year 12 team, it was their last opportunity to represent Goulburn High at a sporting event and it was evident in the way they competed. All students showed respect to the opposition and determination throughout the day. This was evident especially with Ben Rudd, who even after taking a heavy hit to the jaw, wanted to continue to play. Although he had to remain off the field, he encouraged the rest of the team during the match. Unfortunately, they were unable to claim a victory on the day, going down in some tightly contested games.

A special mention must be given to Harry Elder and Bailey Lanham, who were recognised by the Brumbies Development Officers as demonstrating outstanding skill and sportsmanship in their age groups throughout the entire competition.



South Coast Representatives

Congratulations to the following students who gained selection for Athletics

Ursula Kemmis



Brandyn Law



Joseph Kremer



GOULBURN HIGH SCHOOL P&C MEETINGS

WEDNESDAY EVENINGS 7PM STAFF COMMON ROOM

Wednesday November 8th (Annual Christmas Dinner)

Deputy Principal's Report

Mobile technology

At Goulburn High students are only permitted to use mobile technology if they have sought the permission of the class teacher. Students are not permitted to receive phone calls in class. If you need to contact your child, please call the front office. Although the school provides awareness programs to students on a regular basis, we would encourage parents to get advice and support related to the use of technology from the following

website <http://www.schoolatoz.nsw.edu.au/technology> to help raise awareness and counter the inappropriate use of technology by their child.

Parent Portal

Thank you parents who have been using the parent portal. The parent portal provides you with an opportunity to maintain a closer link with the school to support your child's education. You will be able to monitor your child's period by period attendance, explain absences online, book appointments for parent teacher interviews, access student wellbeing data and approve excursions online, as well as access academic reports online.

As we progress with this initiative, we are confident that the parent portal will become more and more significant in your day to day management of your child's education at our school. Should you experience difficulties please do not hesitate to contact us for assistance. We also look forward to hearing from you about your experience with our parent portal, and any feedback will be gratefully received with a view to adding further functionality and improvement. The following is the web address to access the Parent Portal: <http://web1.goulburn-h.schools.nsw.edu.au/portal>

School Attendance / Leave Passes

A reminder to students and parents/carers that once a student arrives on school premises they must NOT leave the school grounds until the end of the school day. If students need to leave the school for any reason, they must bring a signed permission note from their parents/carer and have it signed by the Deputy Principal. This is then given to the front office so a leave pass can be arranged. Students must carry this pass at all times whilst off school premises.

Students who feel unwell or who are injured during the day must report to Sick Bay (school office). This allows our office staff to assess their needs and contact parents.

If you need to collect your child unexpectedly during the day, please contact the front office to arrange a leave pass.

Mr Yogesh Mani and Mr Vero Joseph



DEEGAN'S TRANSPORT
ABN 48 061 819 181

65 CHANTRY STREET, GOULBURN NSW 2580
Ph: (02) 4821 3796 • Fx: (02) 4821 3651
Email: kim@deeganstransport.com • Web: www.deeganstransport.com.au



GOULBURN HIGH SCHOOL



RESPECT	RESPONSIBILITY	RESILIENCE
<ul style="list-style-type: none">• Treat others with dignity• Speak and behave politely• Cooperate with others• Follow teacher instructions• Value the interests, abilities and culture of others• Take care with property• Follow school rules• Listen politely when others are speaking• Think before acting and speaking	<ul style="list-style-type: none">• Attend school every day• Arrive at school and class on time• Be prepared for every lesson• Actively participate in learning• Avoid dangerous behaviour and encourage others to avoid dangerous behaviour• Dress appropriately by wearing full school uniform	<ul style="list-style-type: none">• Develop positive and respectful relationships• Care for yourself and others• Negotiate and resolve conflict with empathy• Take personal responsibility for behaviours and actions• Be open to change and new ways of thinking• Aspire and strive to achieve the highest standards of learning



Year 12 Woodwork Projects

Year 12 Woodwork students spent many afternoons and evenings finishing their major works in time for the HSC markers to arrive and judge their work. A huge 'thank you' must go out to Mr White, who stayed behind after school hours for many days to make sure all his students finished their pieces on time, sometimes until 10pm. Such dedication and help from the teacher is greatly appreciated.

Looking at the cabinets, computer desks and tables, it was worthwhile and we congratulate students and teacher alike. Well done.



What has been happening in TAS?

Technology Mandatory: Year 7 and 8

Year 7 and 8 have been busy creating several projects: Stationary Holder and Spatula

Design Brief: Design and create your own Desktop Stationary Holder using the following guidelines

Material: Radiata pine

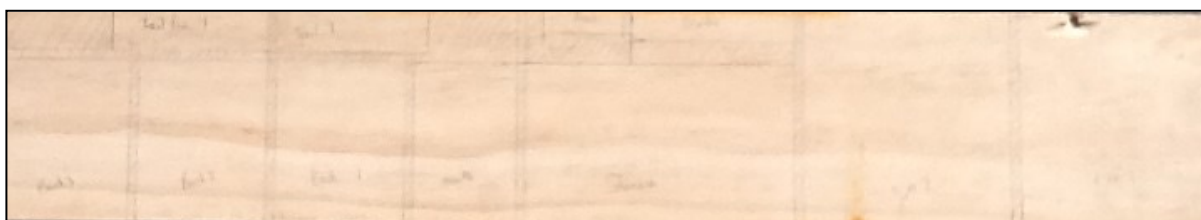
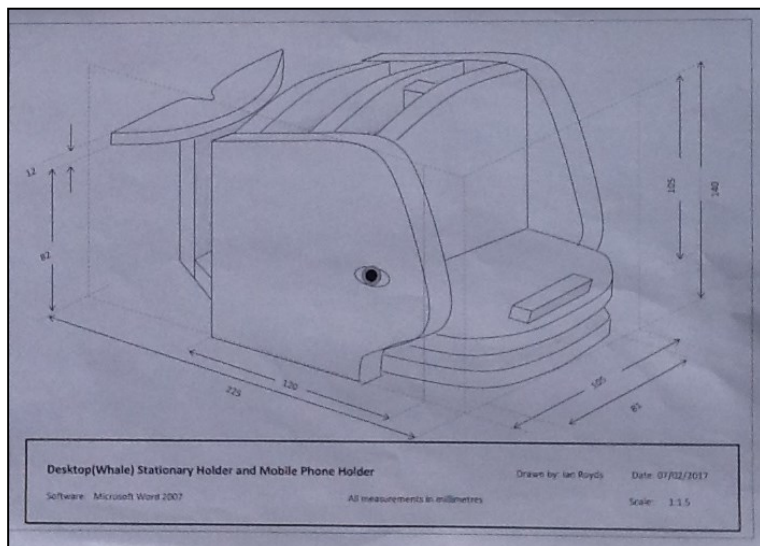

Design Brief: Design and create your own BBQ Spatula using the following guidelines

Material : Aluminium and Radiata pine

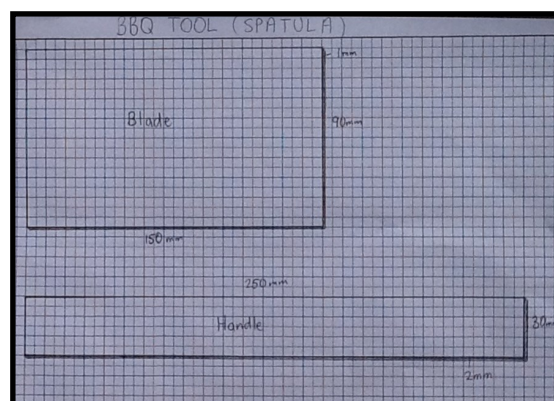

Year 9 Jnr Engineering have been busy creating a Small Garden Fork and a Mouse Trap Car.

Design Brief : Design and create your own Small Garden Fork using the following guidelines

Material – 3 mm mild steel strapping

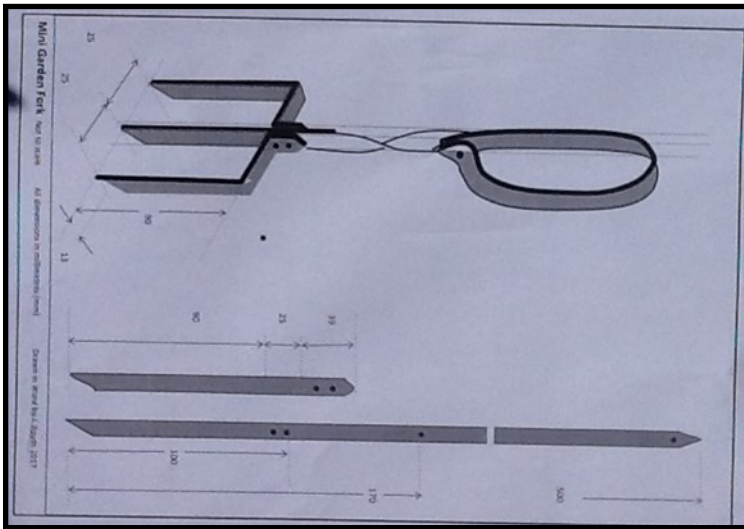

Design Brief: Design and create your own Mouse Trap Car.

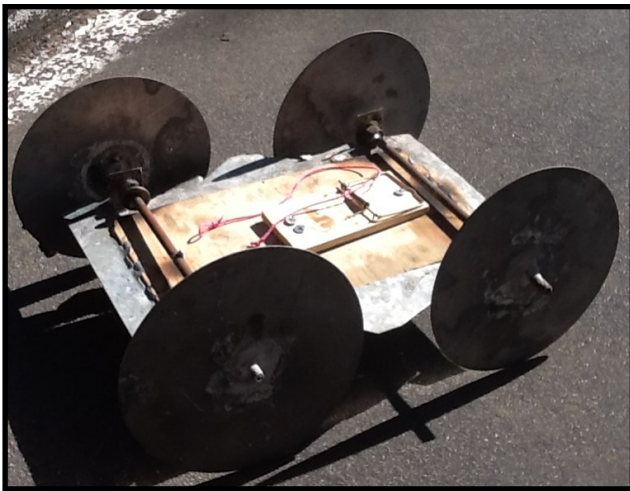

Year 9 Tech Wood have been busy creating their own Mirror Frames.

Design Brief: Design your own mirror frame using a mortise and tenon joint.

Material : Radiata pine

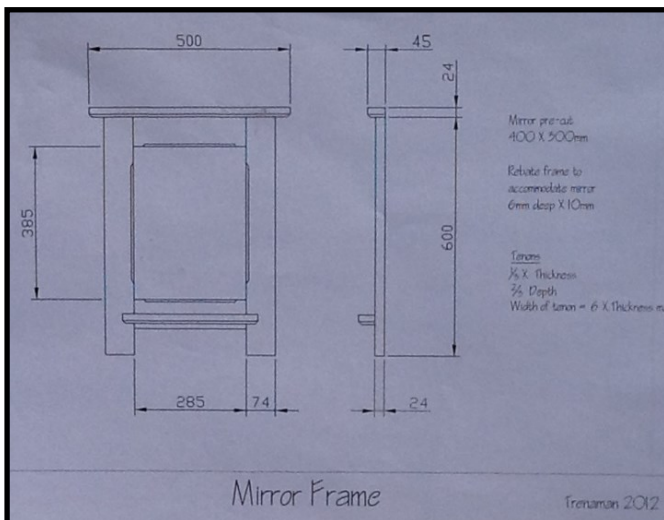



R U OK? DAY™

14 September 2017

Actor Steve Bastoni and Mission Australia's Daniel Strickland presented a short film on suicide prevention last Friday to our year 9 and 10 students. Both men are very involved in the R U OK? initiative and made sure that we all understand how important wellbeing and mental health is in our daily life. All students were invited to start a conversation with their friends to find out how we can make a difference by asking someone

R U OK?



Shaelyn Wilson and Alex Lumsdon enjoying riding this week at the Rosemont Horse Complex.



Careers Desk

Year 12 UAC REMINDER:

Applications for tertiary study in 2018 & SRS applications will open on **Wednesday 2 August 2017** and close on **Friday 29th September**.

Educational Access Schemes (EAS) aim to help students whose education has been negatively affected during Year 11 and/or Year 12 receive an offer to university.

EAS applications open on Wednesday 2 August 2017.

YEAR 10 WORK EXPERIENCE:

Congratulations to the following students who have completed Work Experience. A big thank you to the employers for supporting the students and providing them with such a valuable opportunity.

Taylor Flood	Stacks Law Firm
Kyi Fitzgibbon	Landmark
Thomas Gallivan	Ron Trinder Painting
Madalyn Newing	Goulburn Base Hospital

Goulburn Tafe Short Courses :

Year 12 may be interested in the following courses being offered by Goulburn Tafe in Term 4.

RSA - \$190
RCG- \$150
Food Safety Supervision \$240
Food Handling \$110
Provide First Aid \$150

Contact Tafe NSW for further details.

Apprenticeship Opportunities:

Roads & Maritime: Civil Construction
Bridge Carpenter

Search Apprentices on <http://iworkfor.nsw.gov.au> . Applications close Sunday 17th September 2017. Open to anyone of working age and different genders.

Essential Energy: Powerline Workers
Zone Substation Electrical Technician Apprenticeships (Queanbeyan)

For more information and to apply, visit essentialenergy.com.au/apprentices.



**GOULBURN
COMMUNITY COLLEGE**

SCHOOL HOLIDAY WORKSHOPS

**MONDAY 25TH SEPTEMBER –
FRIDAY 6TH OCTOBER 2017**

For ages 8 – 15

Goulburn Community College will once again be running their extremely popular holiday workshops @ Workspace2580. Our courses provide affordable, fantastic and fun activities that will cater for all levels of experience and interest.

Go online at www.goulburncommunitycollege.com.au to enroll today!

Workshops are on from 10am to 12 noon. We will also run them from 2pm to 4pm if there is demand.

Cost of each workshop is \$35. Morning Tea is provided

Workshops are @ Workspace2580,

Level 1, 56 Clinton Street

Ph: 02 4821 3350

Email: admin@goulburncommunitycollege.com.au

Monday 25th Sept

Jewellery Jam

Wednesday 27th Sept

Screen Printing

Thursday 28th Sept

Oscar winning iMovies

make it easy to turn your photos and video clips into stunning movies or trailers and share them with the world.

Tuesday 3rd Oct

I love you Monster machine sewing

Thursday 5th Oct

Fun with Photoshop

Create and enhance your photos, images, 3D artwork, and more

Friday 6th Oct

Makoy Makoy

Makoy Makoy is an invention kit for the 21st century. Turn everyday objects into touchpads and combine them with the internet

Eisteddfod public speaking and performing competition

Charlotte Hargan, Year 9, participated in the 2017 Goulburn Eisteddfod competition last week. She had a prepared speech on 'Why voting is important' and completed an impromptu speech on 'Learning a new language opens up a world of new opportunities'.

She placed first in impromptu and second in prepared speeches, and is looking forward to competing again next year. Charlotte is also part of our GHS debating team and was grateful for the opportunity to represent our school and hone her skills in public speaking even further.

Congratulations Charlotte.



Goulburn High School would like to thank all our parents, relatives and friends who have been collecting Earn and Learn stickers and dropping them into our box at Woollies. The box has been emptied and the thousands of stickers are currently being stuck onto the sticker sheets at school.

Please keep collecting until September 19. All stickers and sticker sheets need to be handed in at Woollies by Tuesday, September 19 or at Goulburn High School by Thursday, September 21. Thank you for supporting our school. Mrs Anable.